

ACCESSORIES

GROUND DETECTOR FUSE BOX

PROVIDES 600 VOLT, 100,000 AIC FUSE PROTECTION FOR GROUND DETECTOR PRIMARIES. FUSES ARE INCLUDED.

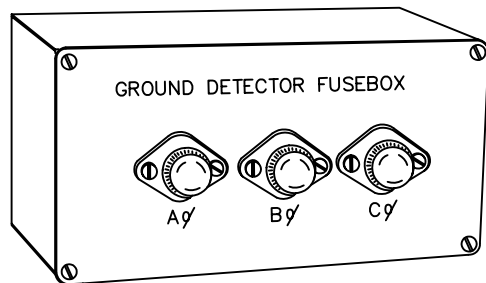

CATALOG NO. 'GDFB'
(NEMA 1 ENCLOSURE)
4"H X 8"W X 3 3/4"D

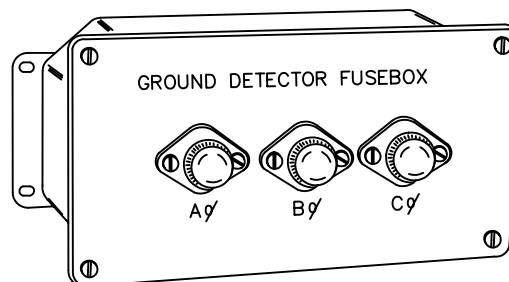

CATALOG NO. 'WP-GDFB'
(NEMA 3R ENCLOSURE)
4-3/4"H X 8-1/2" X 3"D

SWITCHBOARD MOUNTING FRAME

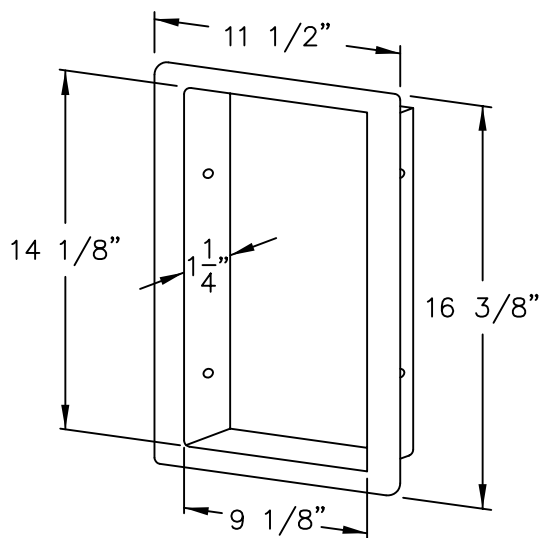

THE SWITCHBOARD MOUNTING FRAME ALLOWS MODEL XVAP GROUND DETECTORS TO BE MOUNTED SEMI-FLUSH IN THE FRONT OF SWITCHBOARDS OR OTHER ENCLOSURES. FOR NEMA 1 APPLICATIONS ONLY.

RECOMMENDED CUT OUT FOR MOUNTING FRAME 9-1/2" W X 14-1/2" H

CATALOG NO. 'GDMF'

'XVAP' GROUND DETECTOR SHIPPING WEIGHT APPROXIMATELY 20 LBS.
F.O.B. CHICAGO
TERMS OF PAYMENT 2% 10 - NET 30 DAYS
ALL ORDERS SUBJECT TO APPROVAL OF CREDIT



ERICKSON ELECTRICAL EQUIPMENT CO.
475 BONNIE LANE • ELK GROVE VILLAGE, IL 60007
TELEPHONE: (847)-640-7701 / 1-800-952-7225
FAX: (847)-640-0565